

ANCHORING TYPE MOUNTS: 9AT & 10AT

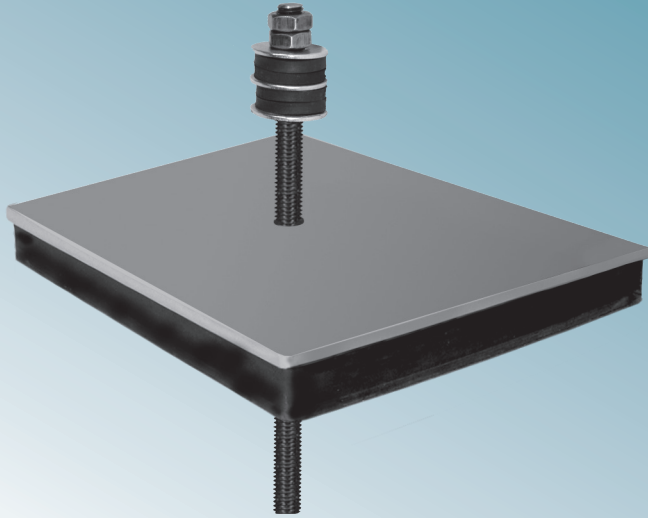

- Elastomer vibration & shock mount
 - protects environment against transmitted vibration & shock
 - protects sensitive equipment from incoming vibration & shock
- Proper machine support
- Proprietary elastomer cushions
 - oil and chemical resistant
 - multiple hardness & thickness for better isolation effectiveness
 - neoprene, nitrile standard compounds
- Meets OSHA anchoring requirements

CUSTOM DESIGNS & SIZES ARE AVAILABLE

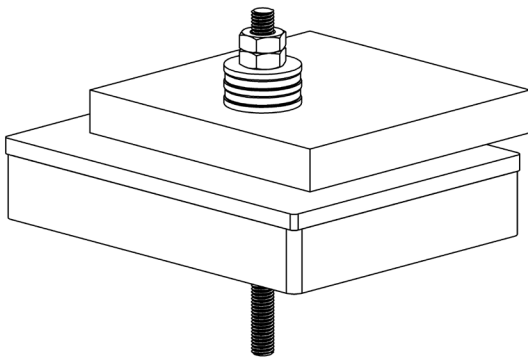
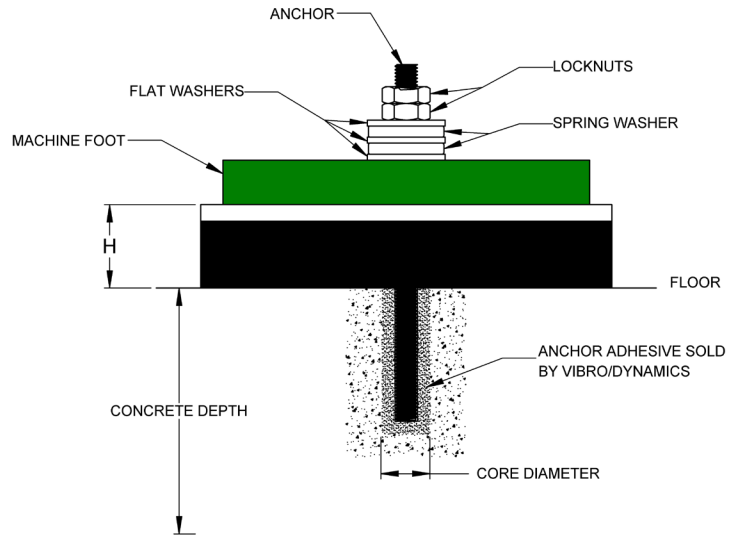
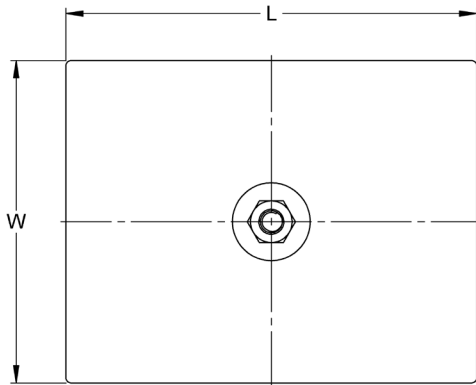

TR (threaded rod) STYLES

TR Anchor Data				Availability	
Dia.	Core Dia.	Core Depth	Max. Torque	09AT-TR	10AT-TR
5/8-11	0.75	3.13	45 ft/lb	Yes	Yes
3/4-10	0.88	3.50	45 ft/lb	Yes	Yes
1-8	1.13	4.00	80 ft/lb	Yes	Yes
1.25-12	1.38	5.00	125 ft/lb	Yes	Yes

Isolator		Capacity (lbs)	L	W	H* ±1/8"		Weight (lbs)
Series	Model				Free	Loaded	
	9ATM780	5,100	9.3	7.3	2.5	2.4	20
	9ATM880	6,500	9.3	7.3	2.5	2.4	20
	9ATL180	10,000	9.3	7.3	1.9	1.8	19
	9ATL250	12,500	9.3	7.3	1.9	1.8	19
	9ATL350	16,000	9.3	7.3	1.9	1.8	19
	9ATK225	13,000	9.3	7.3	1.5	1.4	18
	9ATK275	16,000	9.3	7.3	1.5	1.4	18
	9ATK375	19,000	9.3	7.3	1.5	1.4	18
10AT	10ATM800	11,500	10.8	8.8	2.6	2.5	32
	10ATM1200	15,000	10.8	8.8	2.6	2.5	32
	10ATL450	15,000	10.8	8.8	2.0	1.9	29
	10ATL600	19,000	10.8	8.8	2.0	1.9	29
	10ATL900	25,000	10.8	8.8	2.0	1.9	30
	10ATK650	26,000	10.8	8.8	1.9	1.8	28
	10ATK950	26,000	10.8	8.8	1.9	1.8	28

* Does not include the thickness of the shim layers.

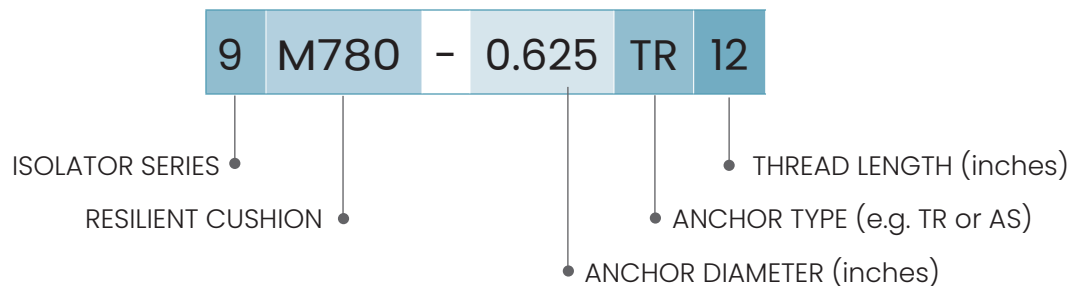

Installation Tools and Equipment

During the installation, you will need the tools for leveling a machine, (i.e open-end or box wrenches to fit the locknut and a calibrated machinists' level) A hydraulic jack capable of supporting at least half of the machine weight should be used to support the machine feet while installing shims to adjust the machine level condition.

Preparation of Foundation Surface

Ideally, the isolators should be set on a dry, flat, and level concrete surface with a smooth trowel or flat finish. The surface does not have to be smooth, ground, and polished, but there should not be any holes, joints, crack, or bumps in the floor surface directly under the isolator. Remove all loose concrete, chips, oil, grease, and water from the foundation surface that will support the isolator.

Preparation of Machine Feet

Before installing the Vibro/Dynamics isolators, remove all loose concrete, chips, oil, grease, and water from the machine feet or base. Clean out the mounting holes in the machine feet. To obtain a uniform bearing surface, the bottom of the machine feet should be clean and flat where they make contact with the top of the isolator. In some cases, it may be necessary to scrape, file, or grind the bottoms of the machine feet. After cleaning, inspect the machine legs and feet, and repair or replace them if they are broken or cracked. The isolator effectiveness is not reduced if the machine foot does not cover the entire area of the isolator support housing.

Additional Considerations

There should not be any solid connections between the isolators or machine and the building structure. Flexible connections are recommended for plumbing and electrical conduit. Floor plates, walkways, railings, and the like should not be attached to both the machine and the building. You want to eliminate paths that would allow impact forces and vibration to bypass the isolators.

NOTE: Isolator data subject to change without notice.

05/10/2019